

MINGDA

# MD-1000D

*Print Bigger ⚡ Faster*



# Eight Advantages

---



5X Faster  
Print Speed



1000\*1000\*1000mm  
Large Build Volume



Dual Extruder



350 degrees High  
Temperature Hot End



New Cooling  
System Design



Camera & WIFI



Free Leveling



Input Shaper

# Fighter jets in industrial large Format 3D printers with **Dual Nozzles**

---

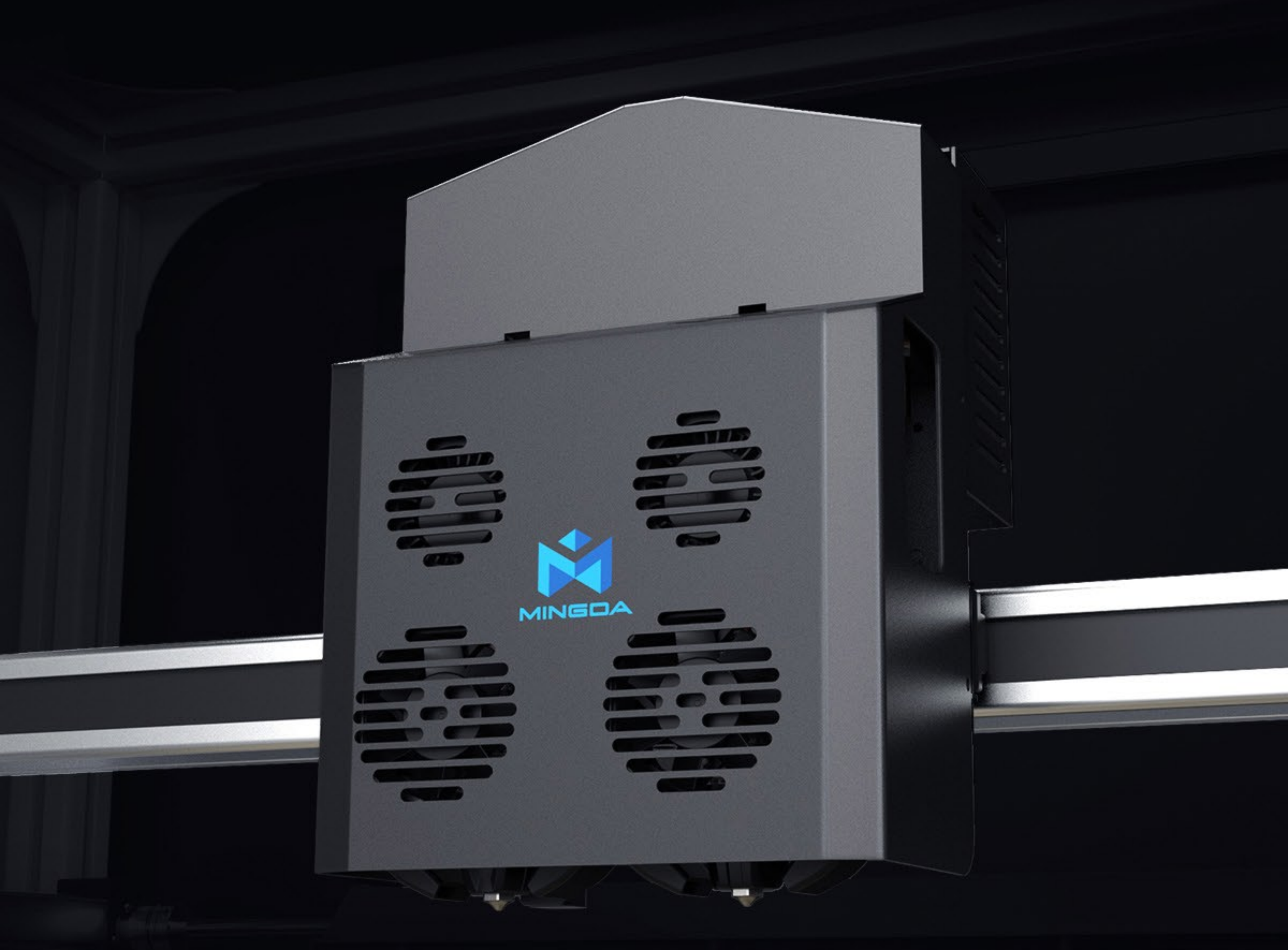

---

**Direct Drive  
Dual Extrusion System**

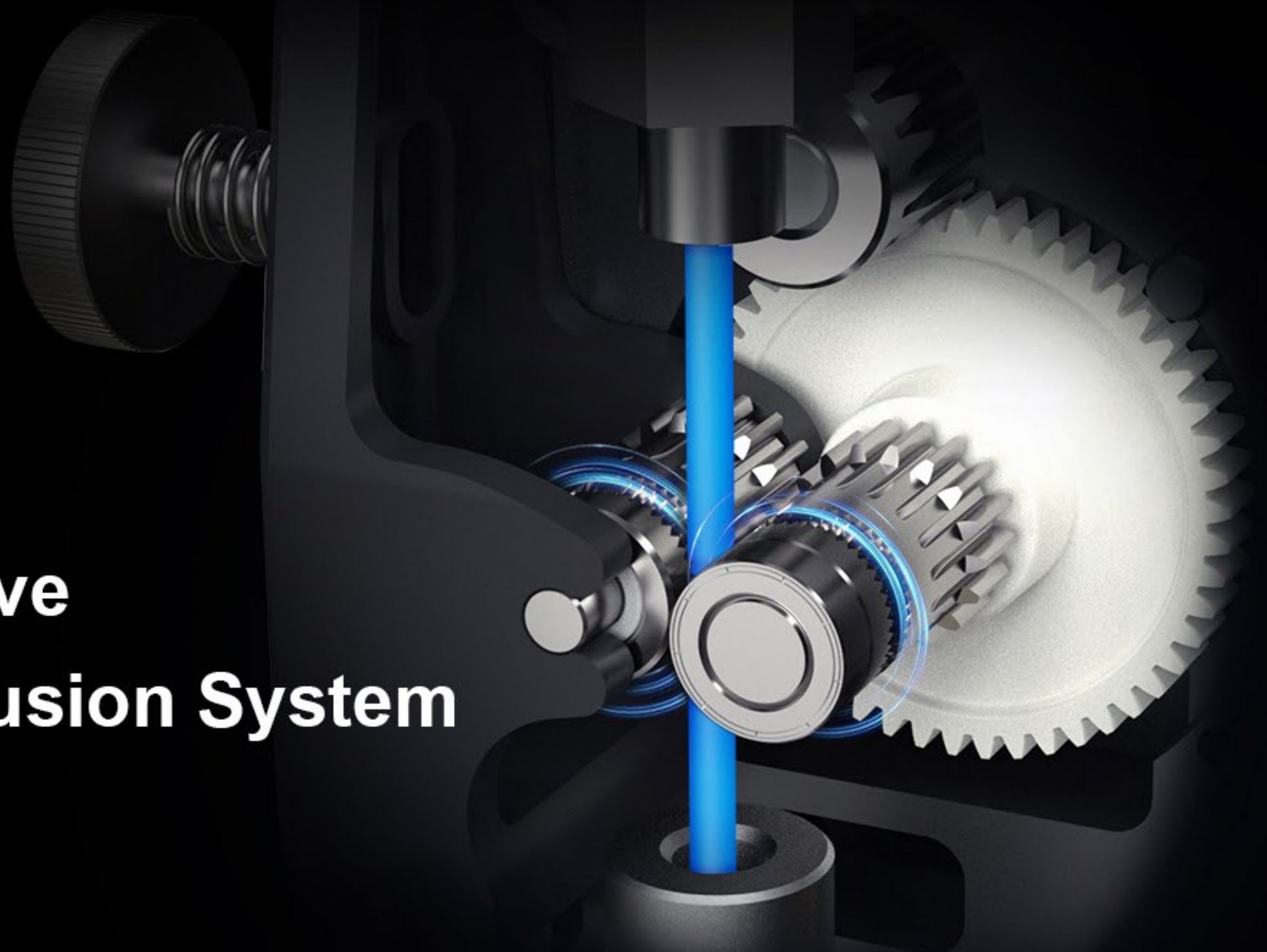

Support materials  
can be printed

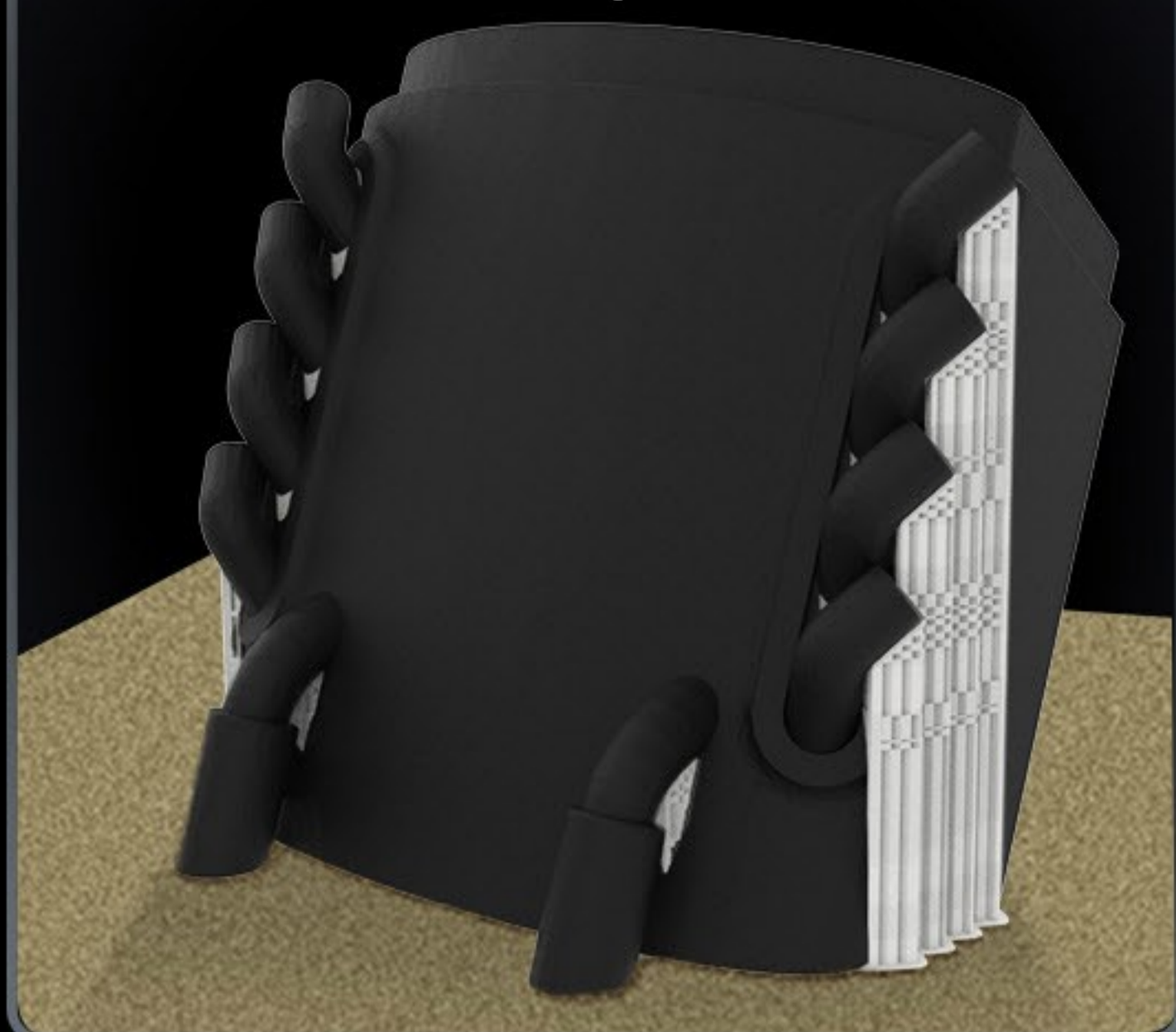

Print two colors  
simultaneously

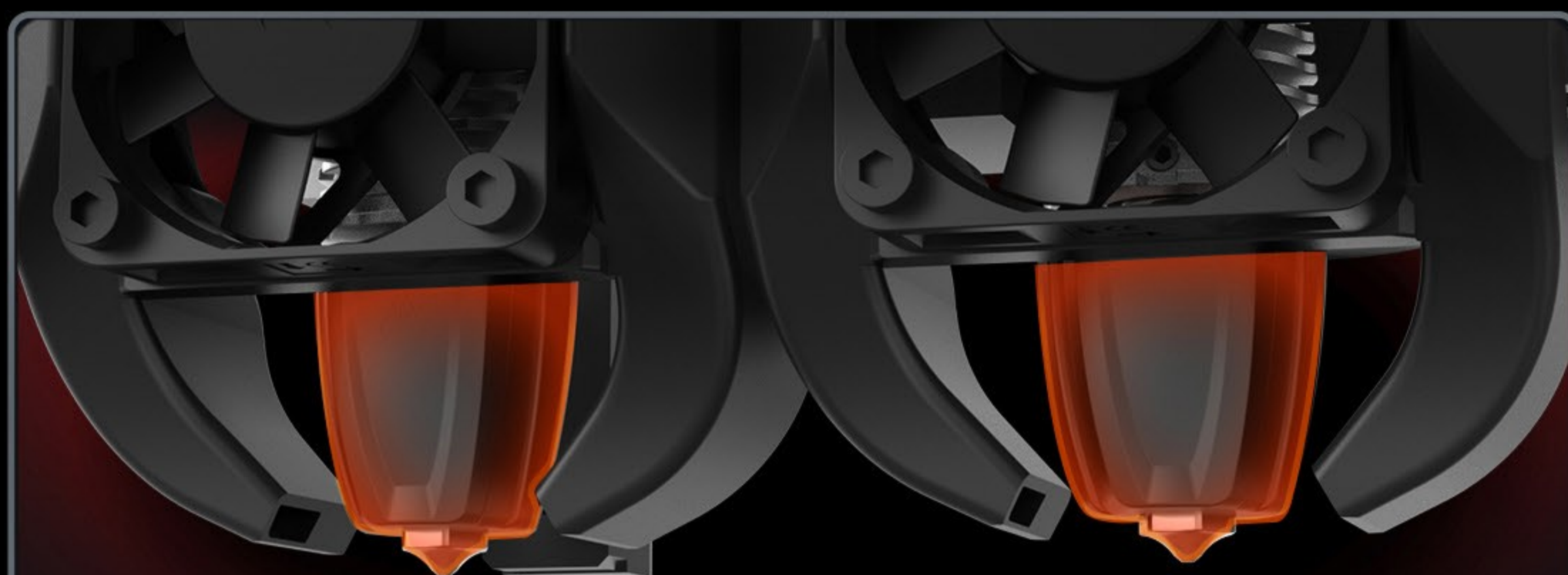

Maximum heating temperature **350°C**

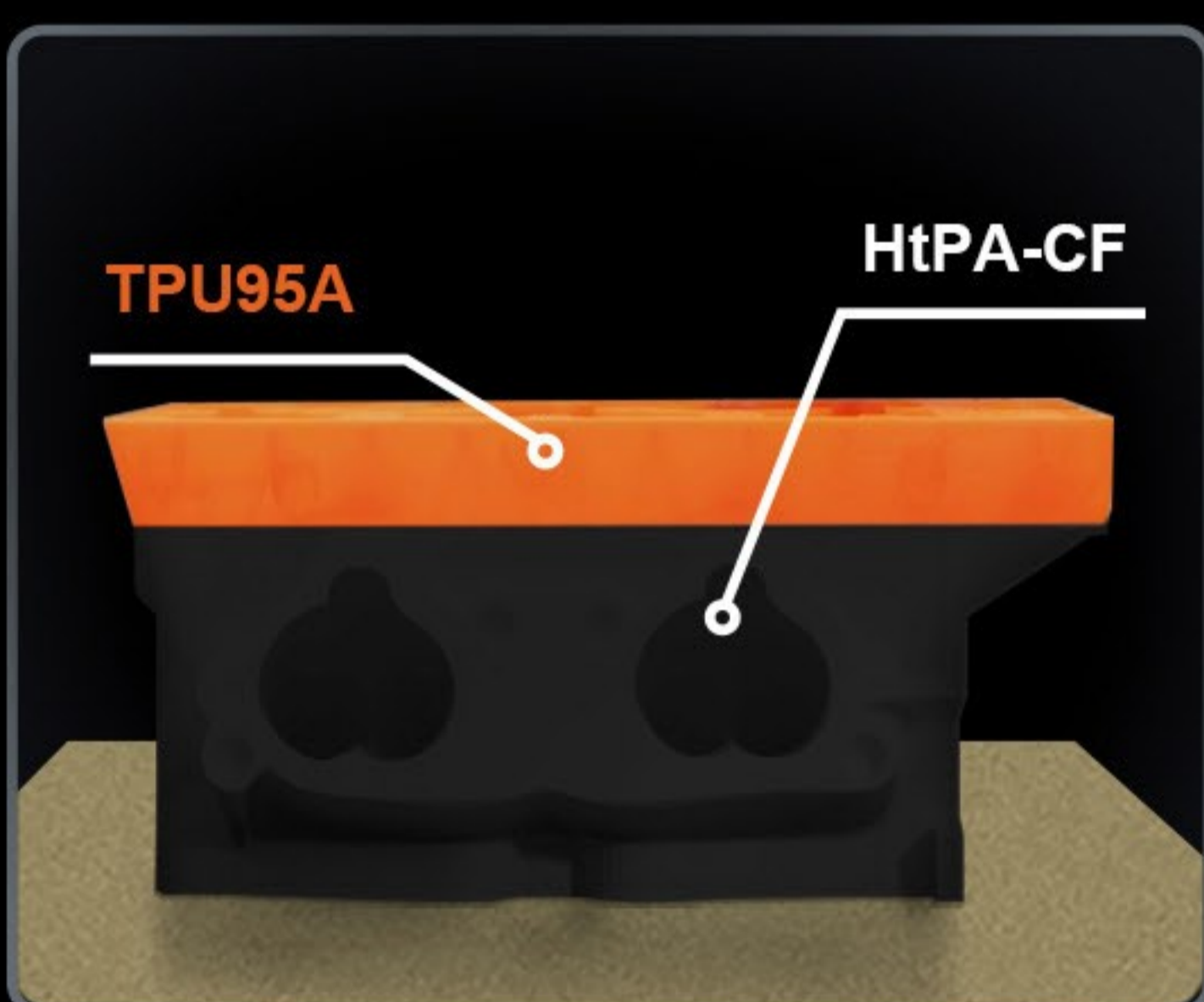

Supports **TPU95A** and **HtPA-CF**,  
while printing **TPU** and **PETG** simultaneously.

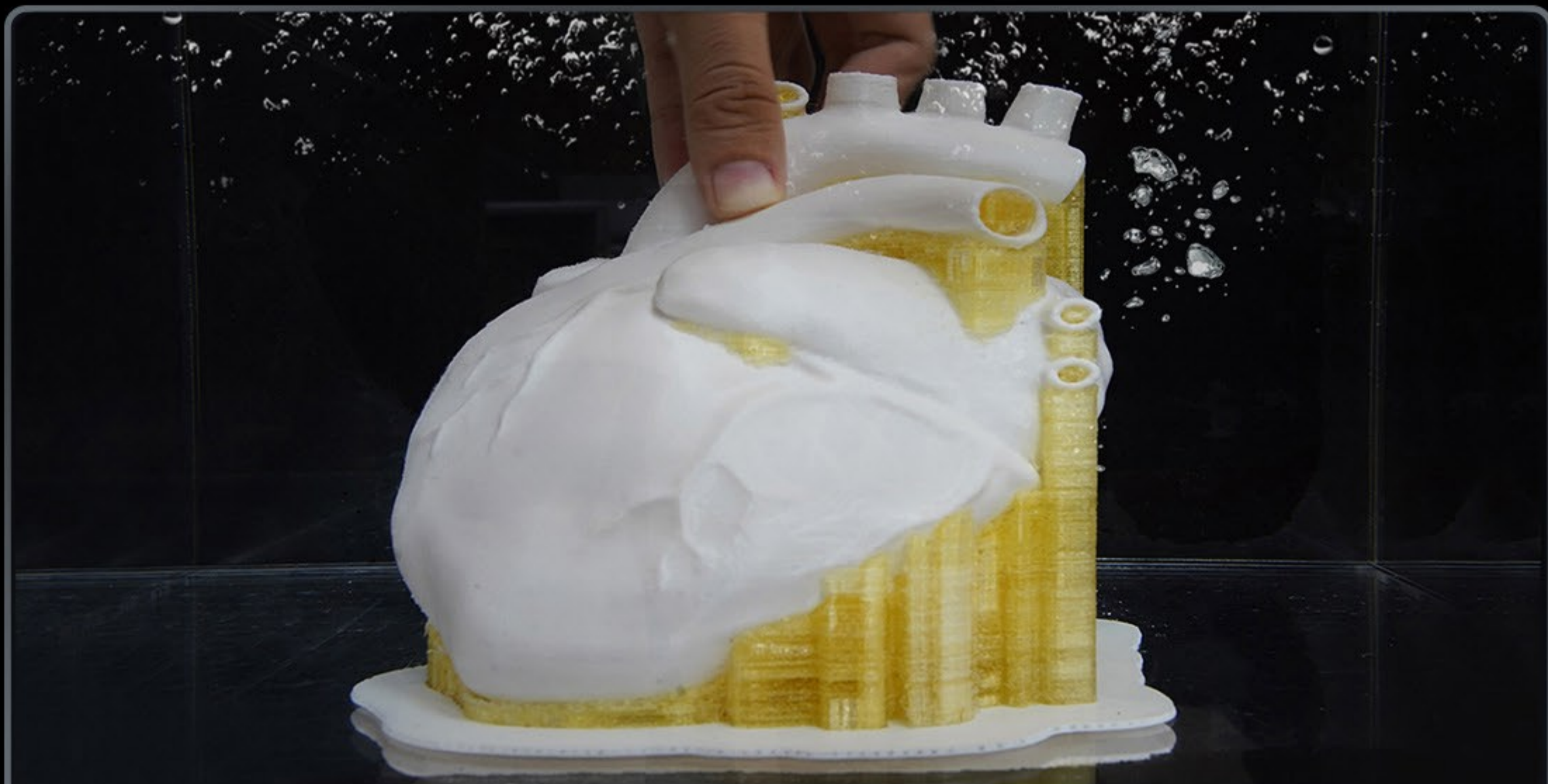

Supports **water-soluble filament** printing

# 5X Speed, Breakthrough in Printing Efficiency Once Again

MD-1000D printing speed up to 300mm/s, 10000mm/s<sup>2</sup> Peak acceleration, only 0.02s speed up form 0 to 300mm/s, achieving ultra-high efficiency printing.

**500mm/s**

Travel speed

**300mm/s**

High-Speed

**40mm<sup>3</sup>/s**

Max Flow

**300 mm/s**



# High Speed, Starting From Slicing

MINGDA Slicer, a new generation of self-developed slicing software, is easy to use, has rich presets, and is deeply optimized for high-speed printing.

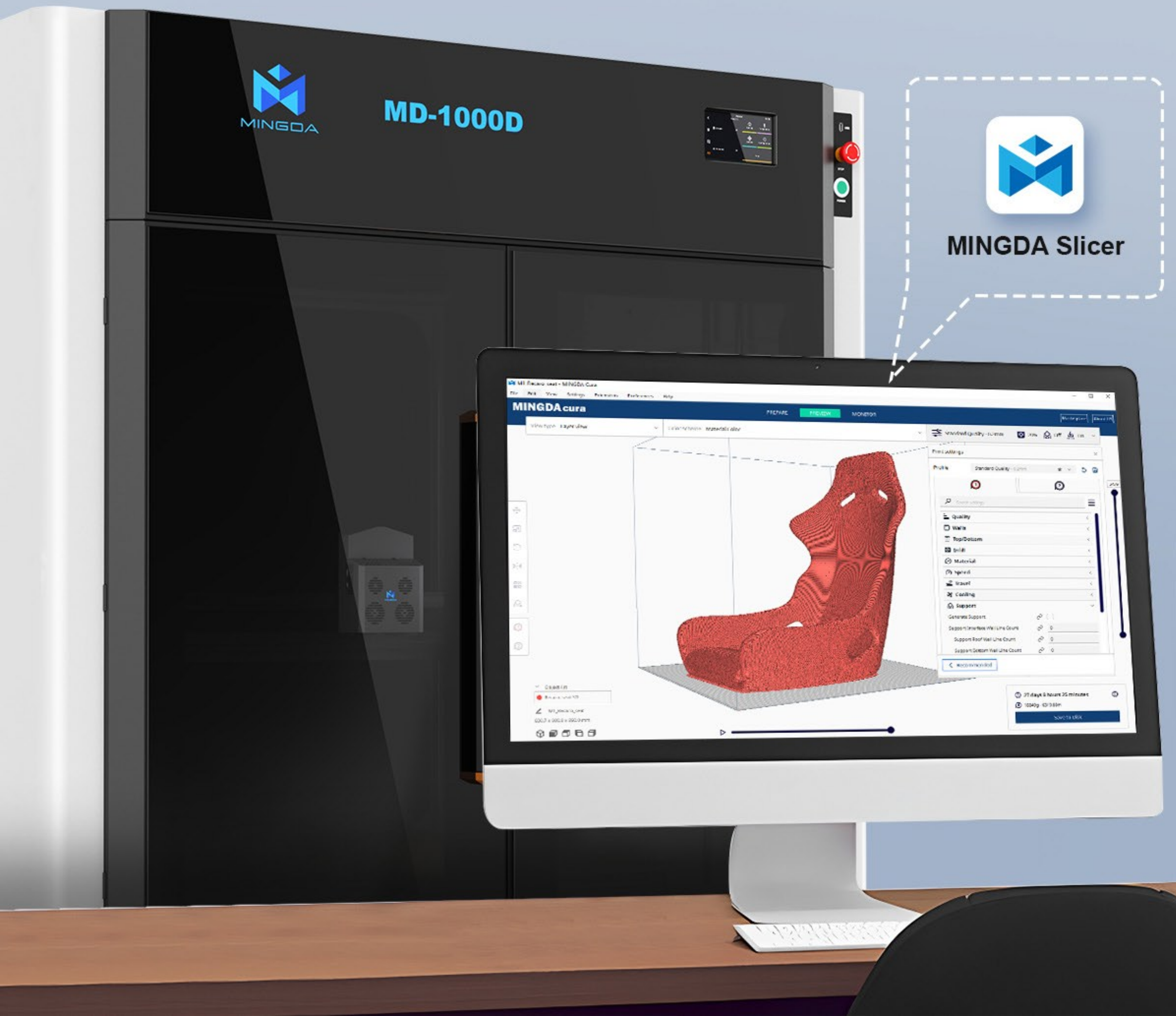

# Automobile seats Case Sharing

---

Filament

**PLA-HF**

Speed

**250mm/s**

Model size

**800\*800\*1000mm**

Printing time

**3 days**



Compare other regular FDM large format printers on the market

Filament: **Ordinary PLA**

Printing Speed: **50mm/s**

Printing Time: **15 days**

\* The experimental data is for reference only

# Large Printing Size

Large Printing Size: 1000\*1000\*1000mm

Machine size: 1680\*1365\*1665mm

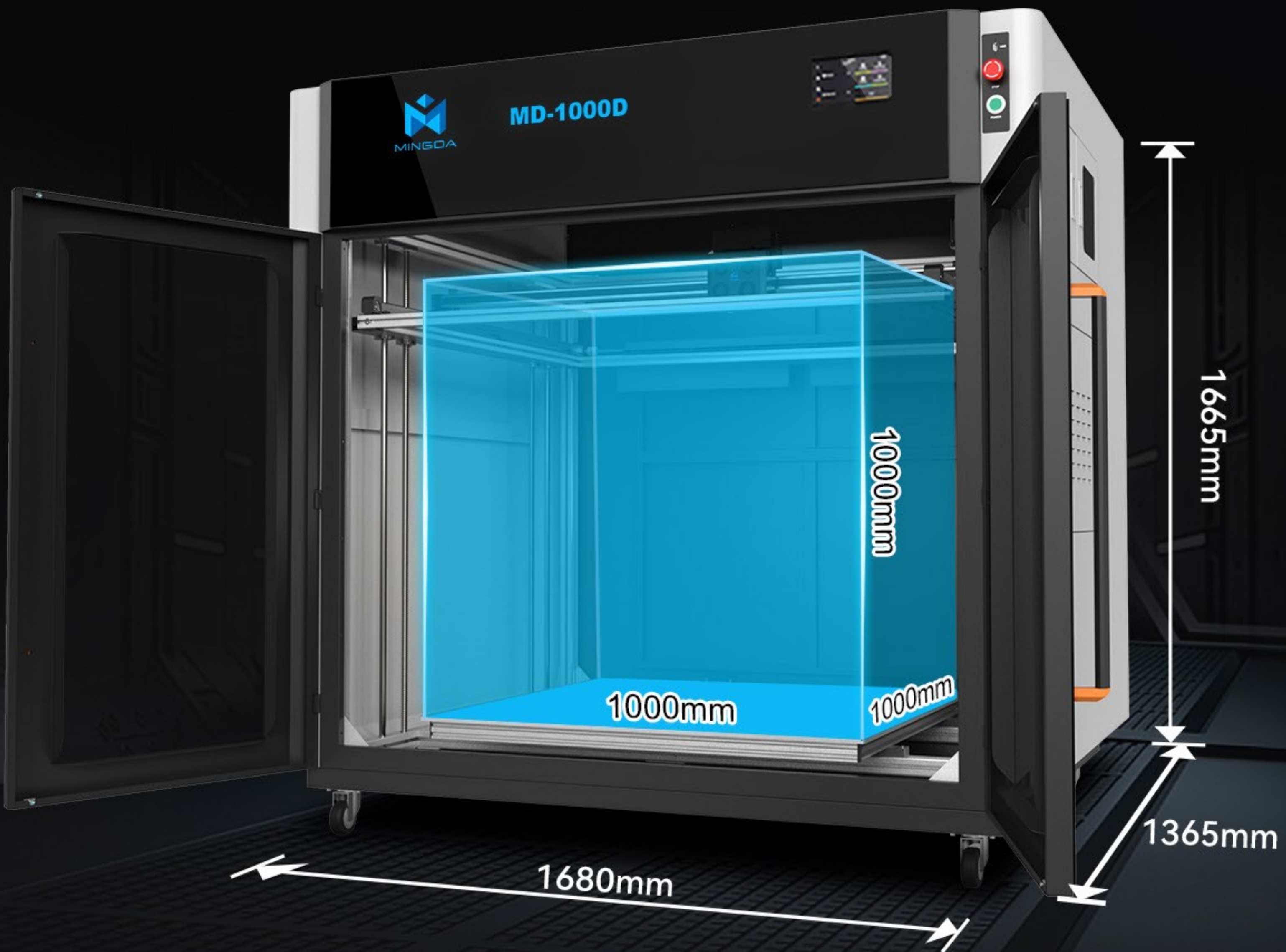

## We Provide The Following Promises

Good after-sales service is the key to test whether a company manufactures high-quality products



One Year  
Warranty



Lifetime  
Maintenance



Factory  
Direct Sales



Quality  
Assurance



Technical  
Support



# Remote Printing Multi-Machine Control

After being connected via WiFi or network cable, the MD-1000D can be remotely printed and monitored in real time. At the same time, it also supports multi machine control, facilitating rapid mass production.



# Hands-free **Auto Leveling**

Making preparation before printing more convenient, Accurate first layer detection.

**10\*10 Points**  
Auto Leveling

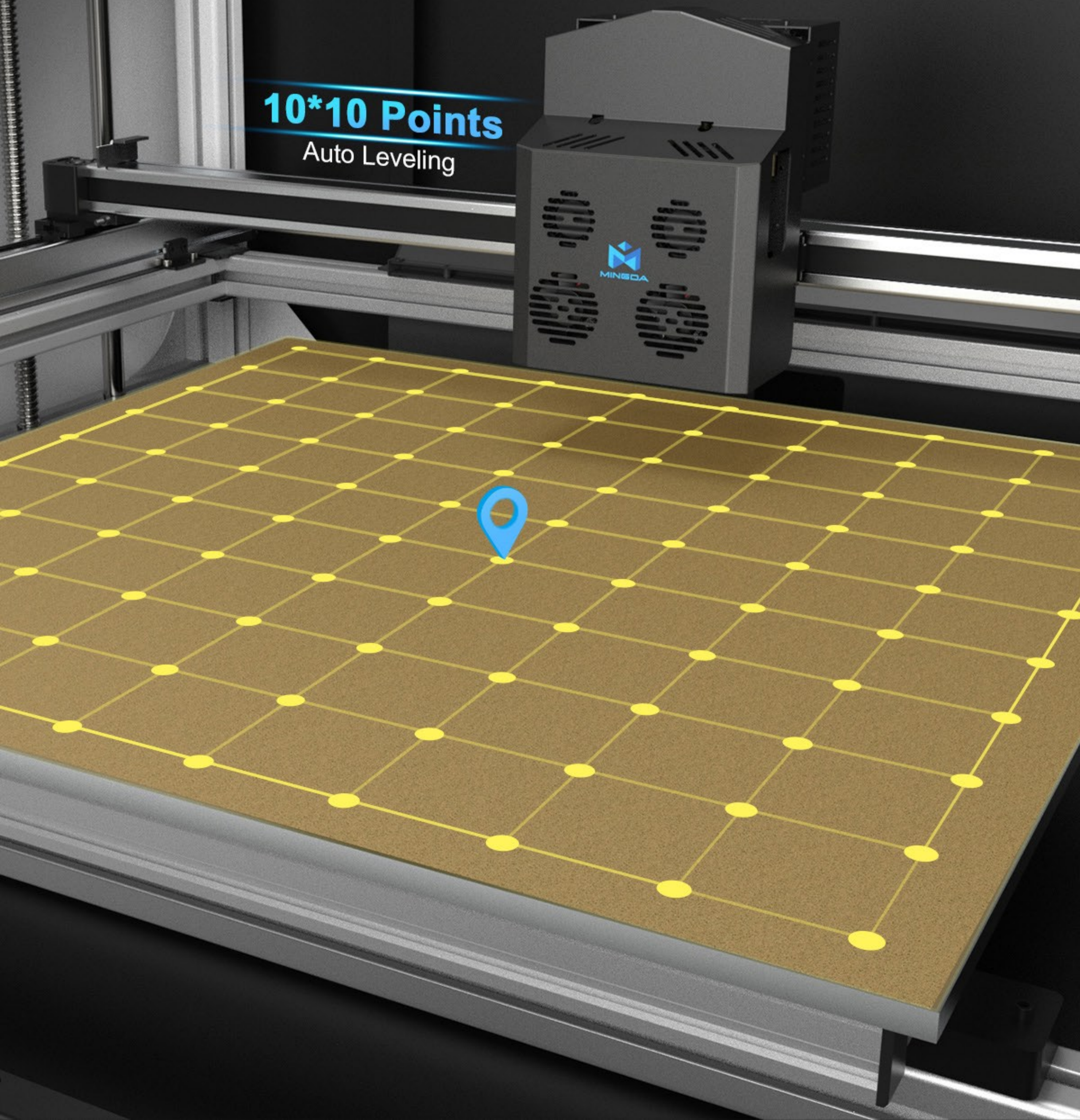

# ± 0.1mm High Precision

Using modular guide rail structure and closed-loop motor design to ensure the stability and accuracy of the printing process

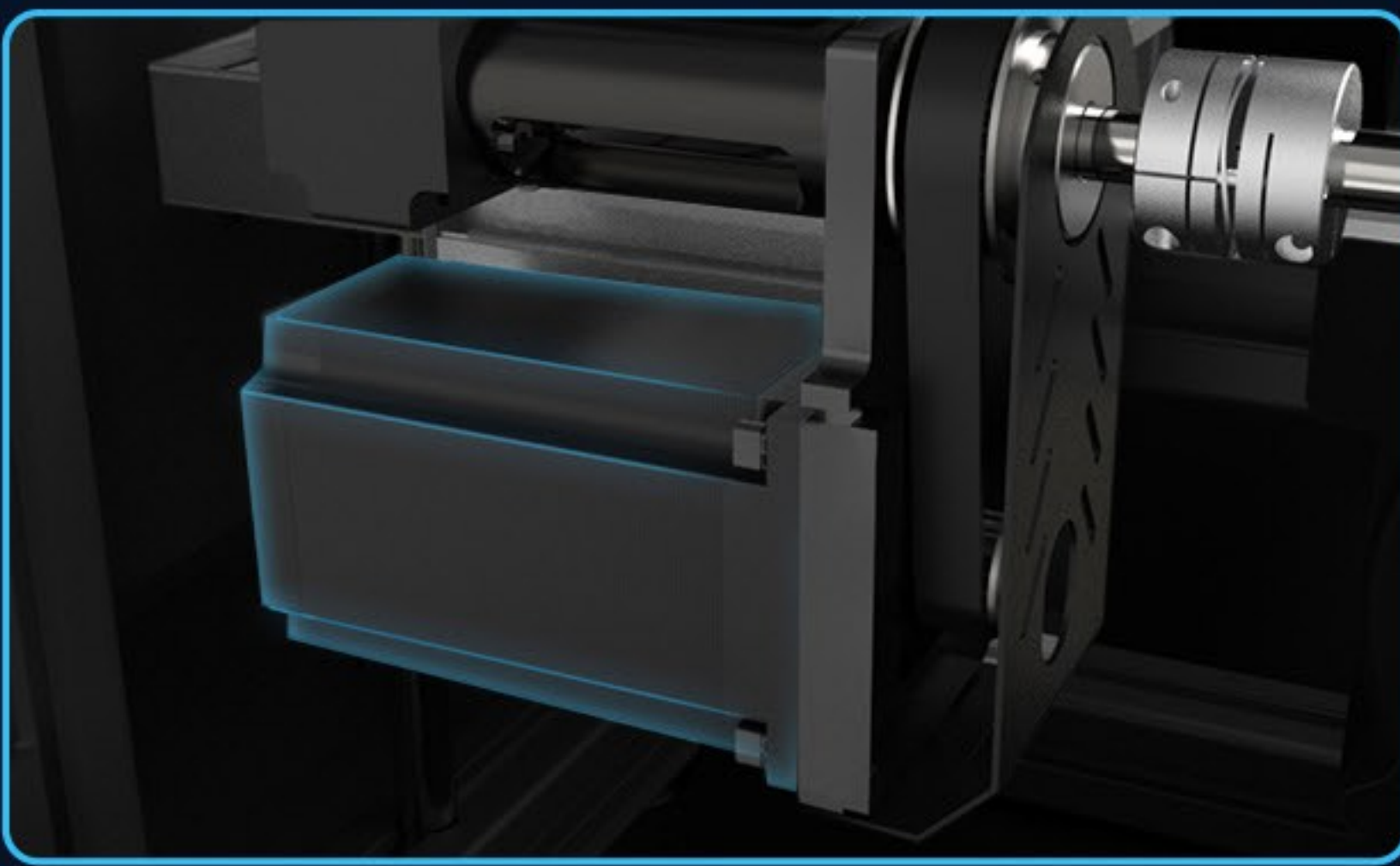
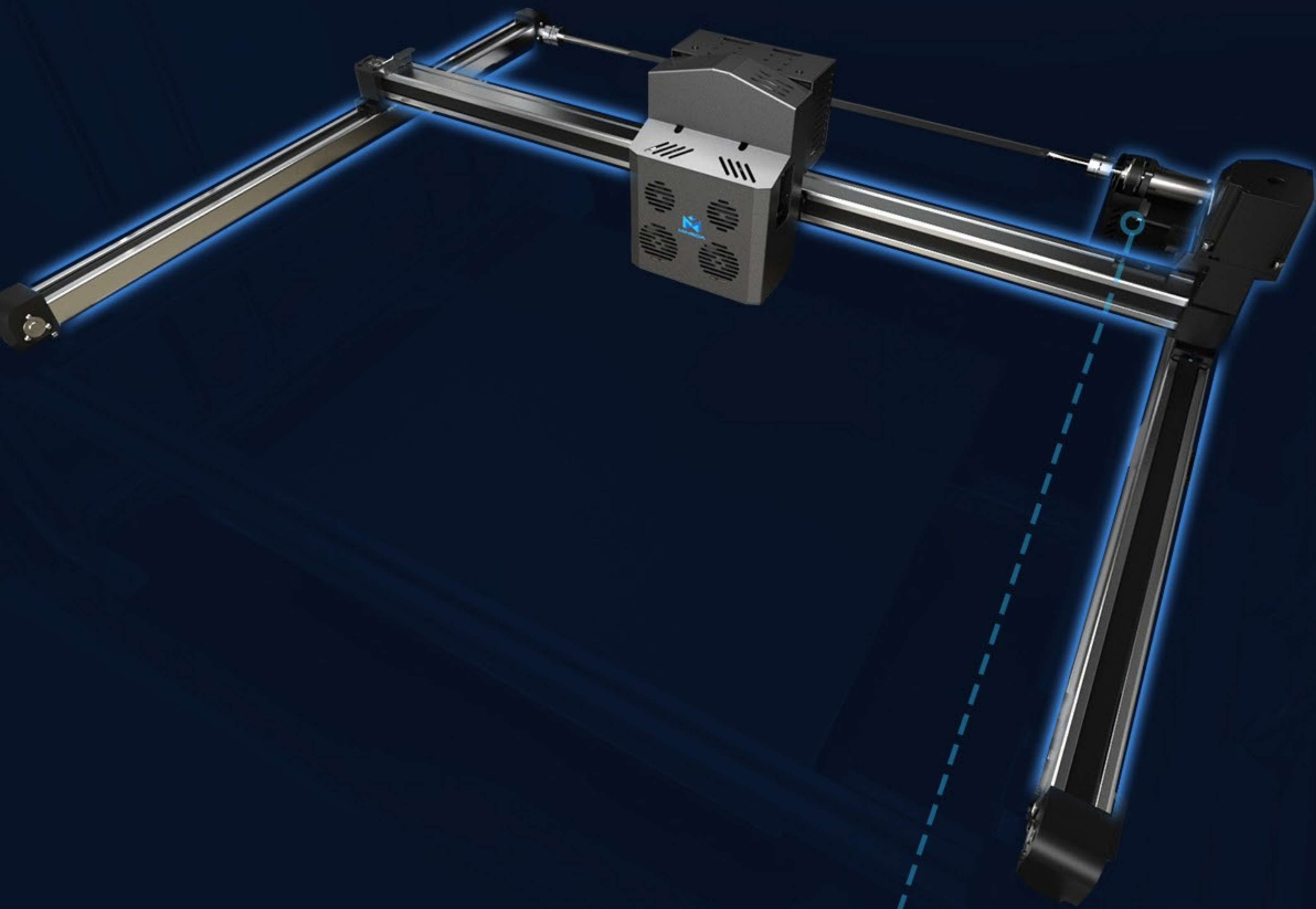

## Closed-loop stepper motors

The MD-1000D is equipped with closed-loop stepper motors. Compared to traditional open-loop stepper motors, it has powerful feedback capabilities, faster speeds, higher precision, and lower heat generation.

# Excellent in Detail



## Input Shaper

Reduce vibration patterns and make the surface smoother

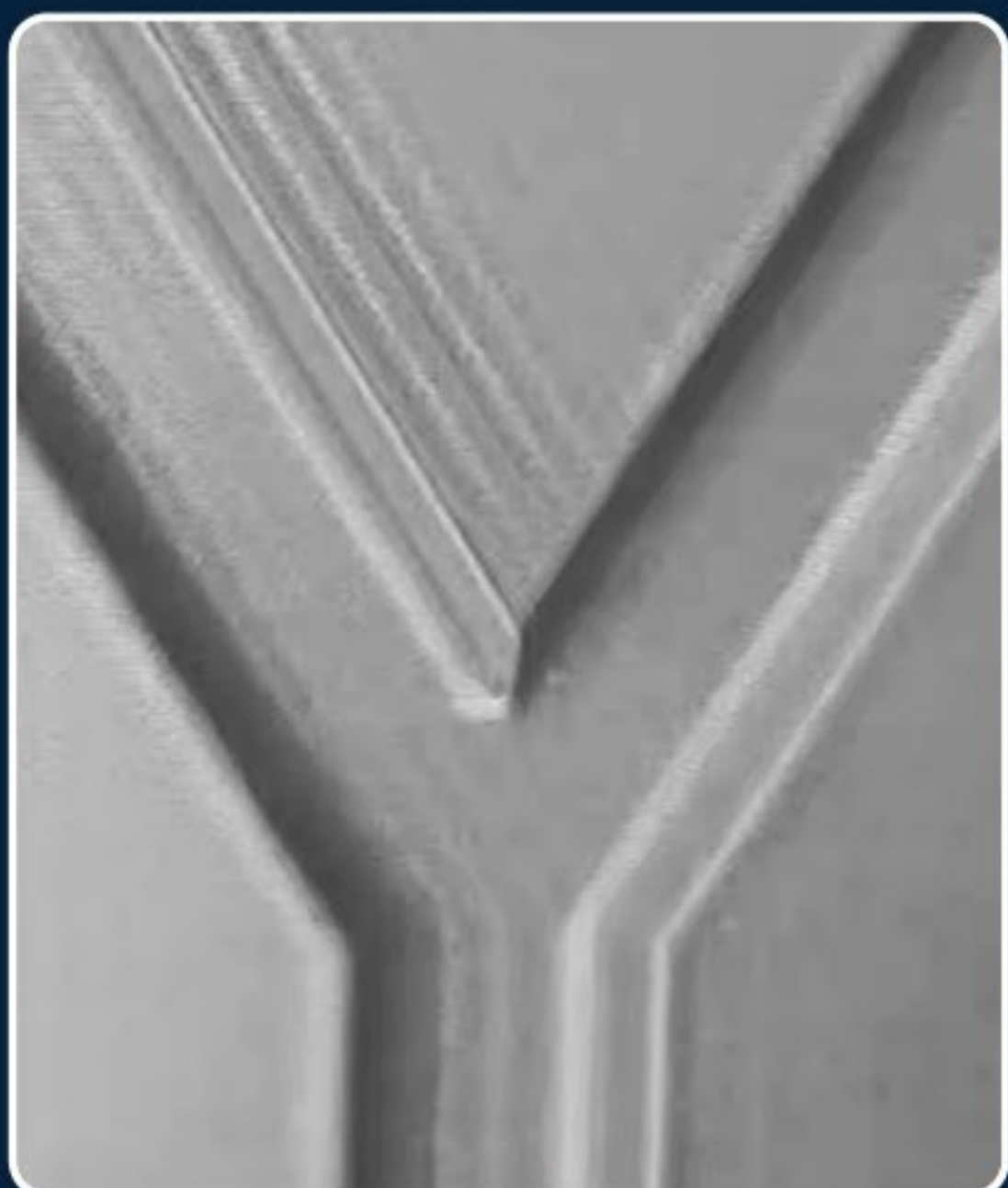

OFF

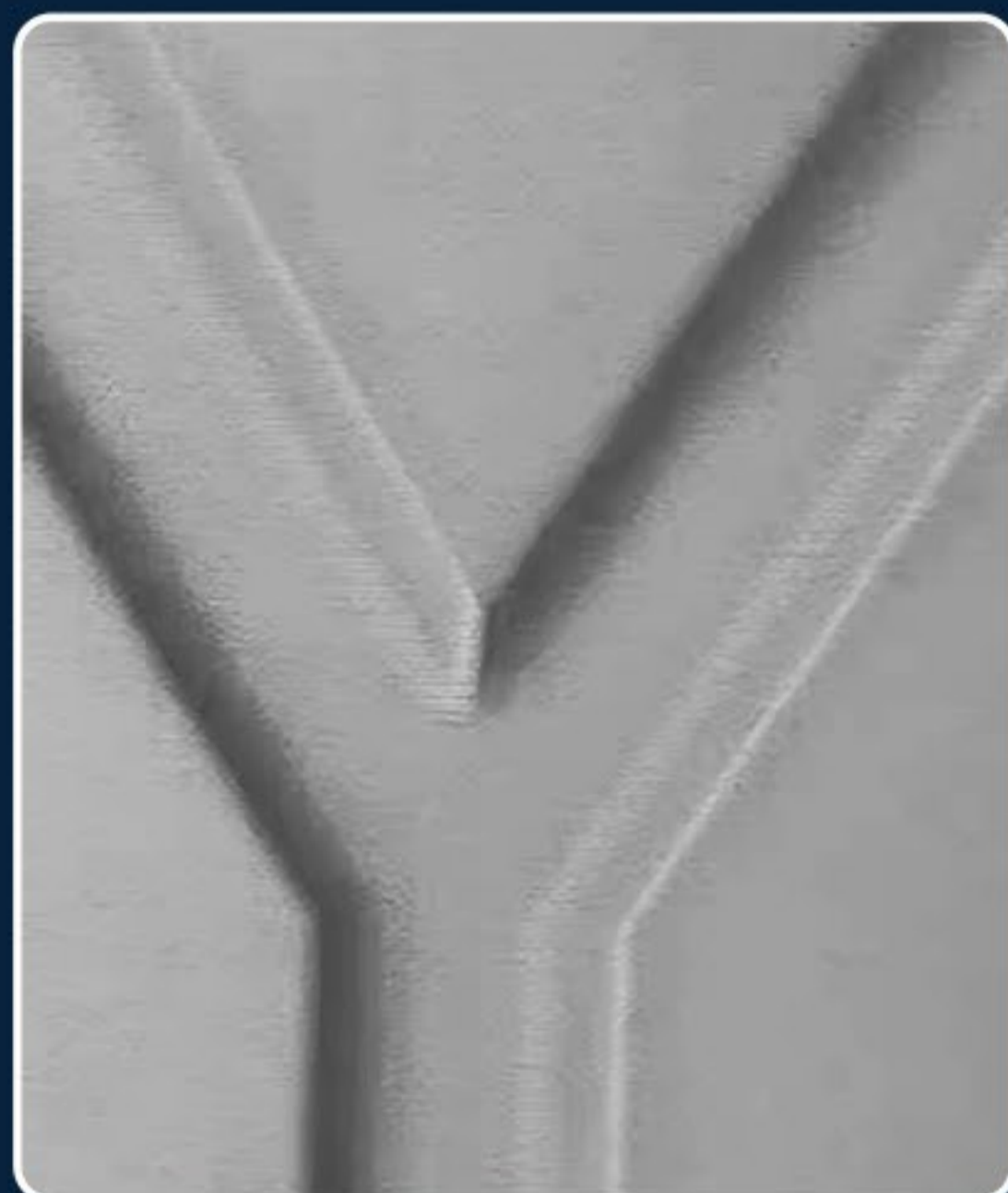

ON

## Flow Control

Improved print quality and accuracy. Flow control allows precise management of the amount of filament being extruded, reducing errors like under/over-extrusion. This leads to smoother prints with sharper details.



OFF

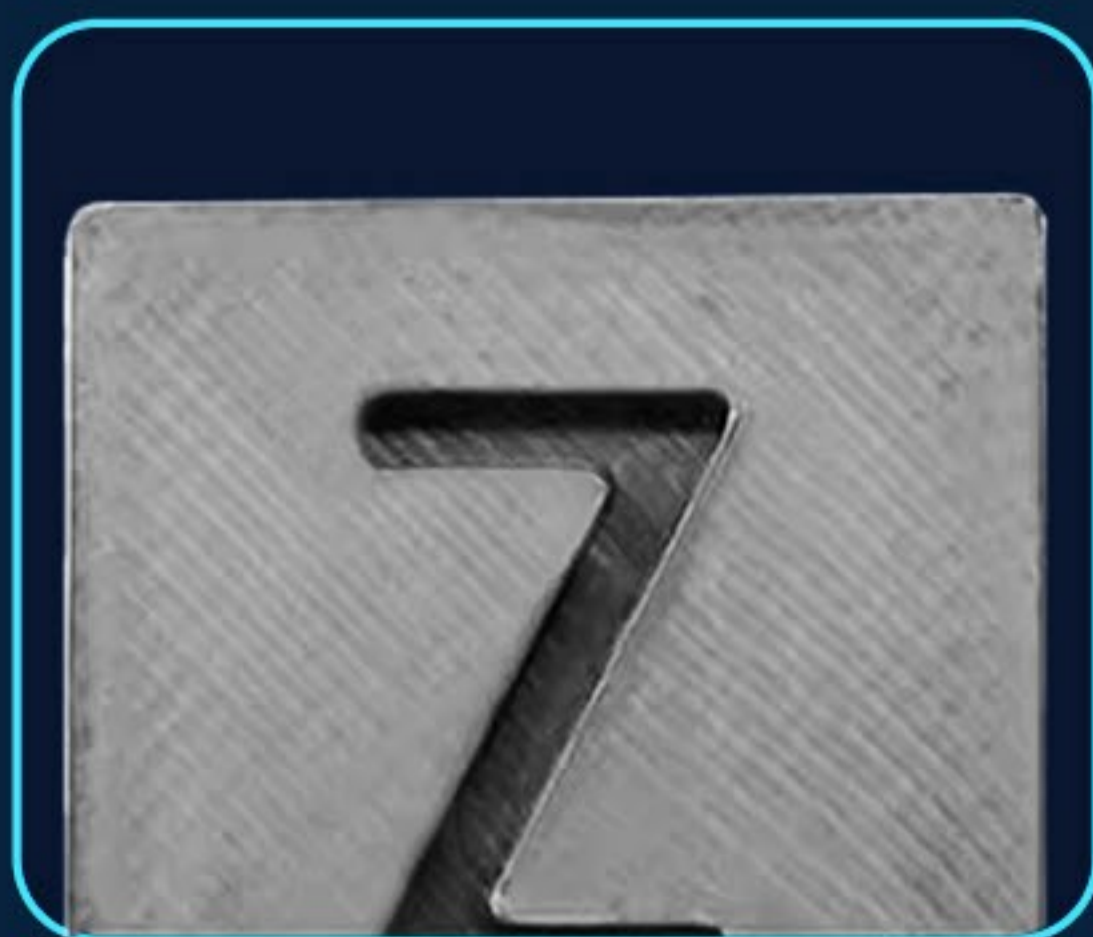

ON

# New Cooling System Design

---

The dual cooling system truly takes model cooling to the next level with an aerodynamic air duct design that blasts models with intensely powerful directed airflow for enhanced cooling capabilities, crafting perfect prints.



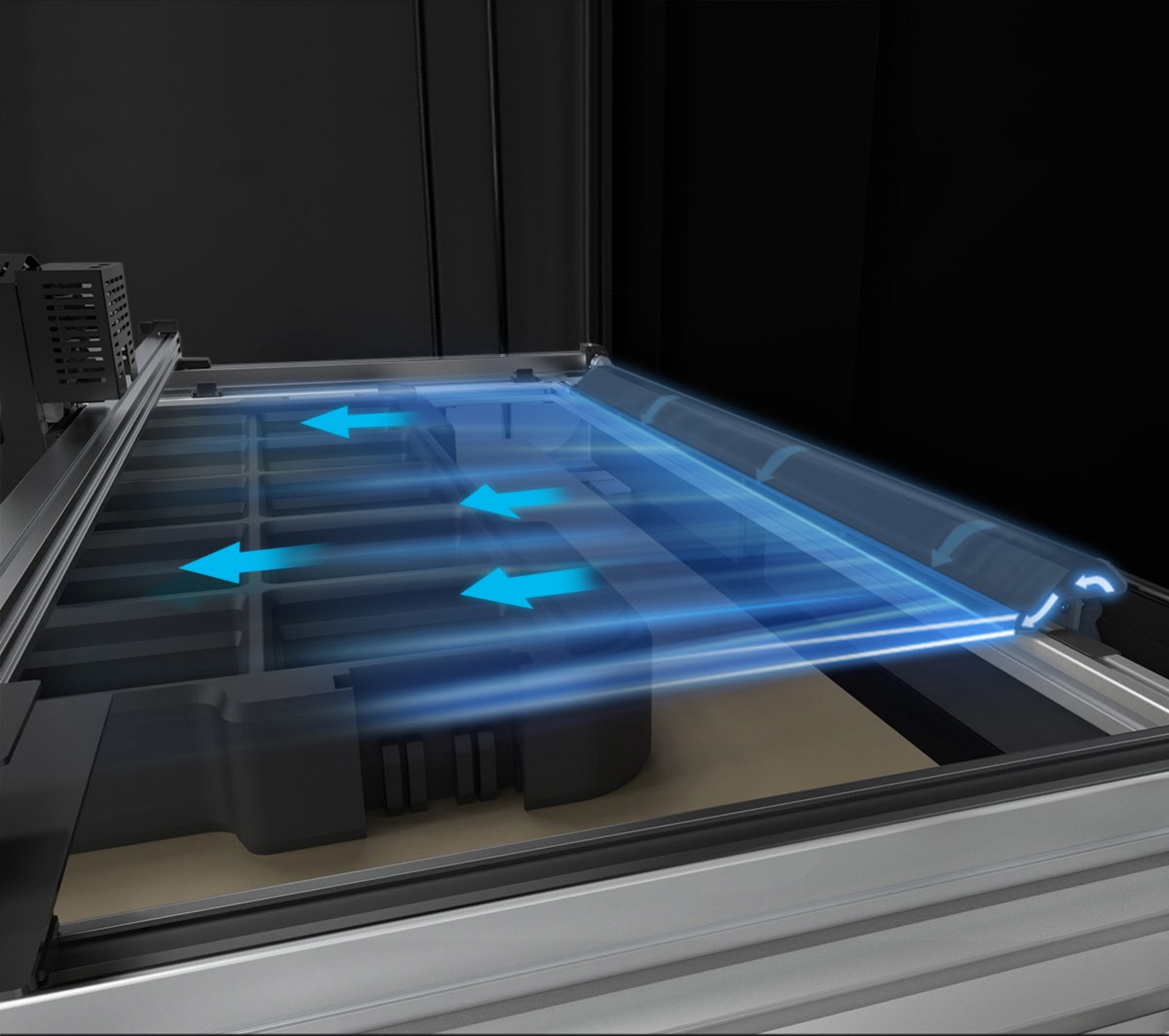

**Speed cool solidification, effectively avoid stringing, warping**



**Mingda air cooling effect**



Regular air cooling effect

# PEI Flexible Printing Platform

It has strong adhesion, high temperature resistance, and is suitable for various consumables. It can be easily removed by bending.

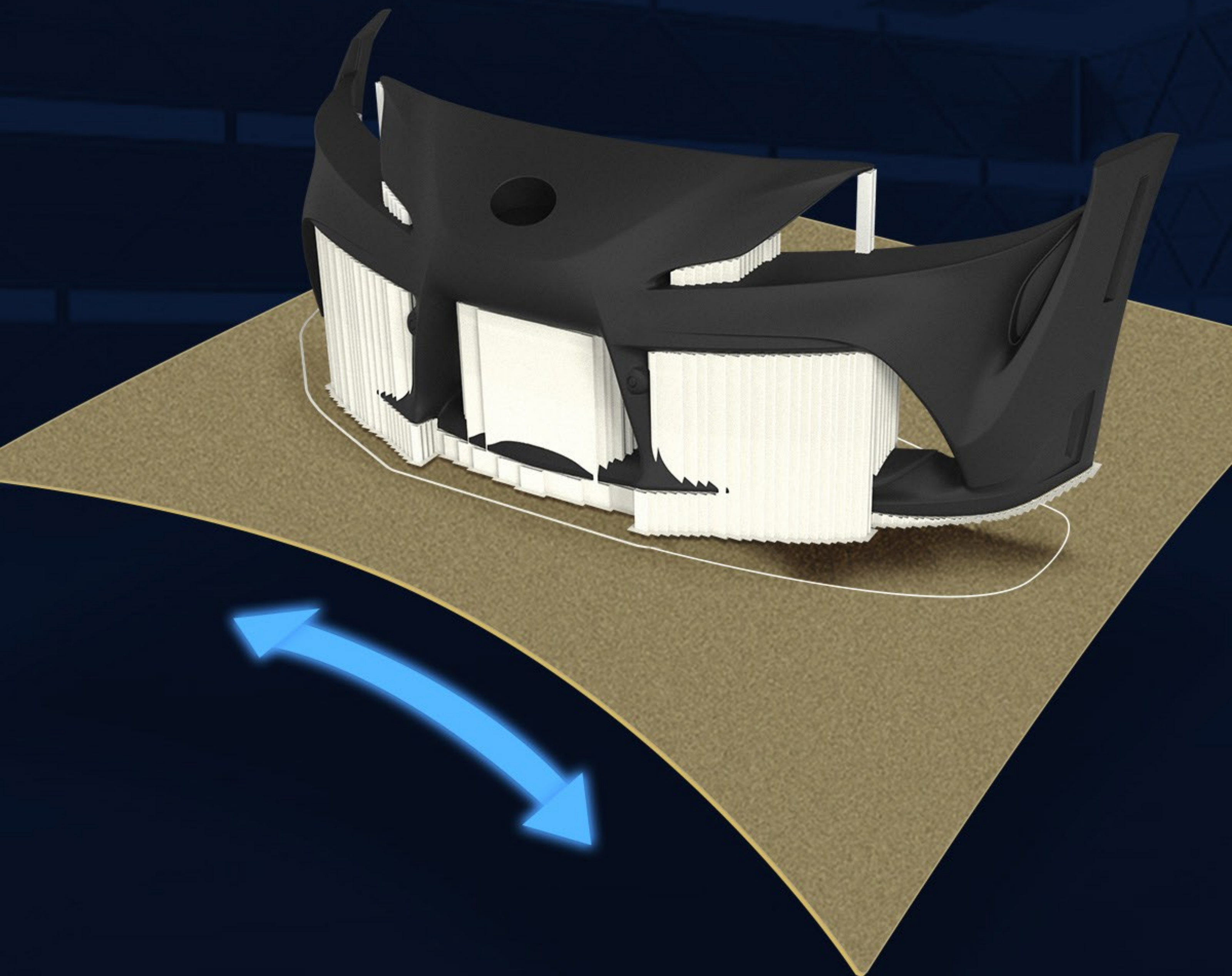

# Quick Heating Bed

---

Max temperature of heating bed is 110°C. Aluminum alloy hot bed, evenly heated, can be heated to 60 degrees Celsius in about 75 seconds; The heating speed remains unchanged at 220V and 110V voltages.





# MINGDA Self-developed Core Hardware Delivers Speedy Smooth Performance.

---

This high-performance **64-bit self-developed motherboard**, powered by the 6-core CPU, ensures fast processing of data and rapid completion of 3D printing tasks. With **32GB of memory**, you can quickly store, export, and print large files with ease.



# 7-inch IPS

## High-definition Large Screen

MD-1000D has a 7-inch IPS 2.1 million high-definition computer screen. Compared with traditional LCD screens, it can see bright, saturated, and natural high-quality images from any angle. At the same time, it is more environmentally friendly and saves electricity.



## Support multiple languages

1. English
2. Danish
3. German
4. Spanish
5. French
6. Hebrew
7. Hungarian
8. Italian
9. Japanese
10. Korean
11. Poland
12. Portugal
13. Russia
14. Sweden
15. Turkey
16. Ukraine
17. Chinese
18. Dutch
19. Czech
- etc

# Self Check when Power on

When power on it can automatically check the status of the extruder, hot bed, camera, automatic leveling, fan, and other components; If there are any abnormalities, a prompt will be displayed on the printer screen for quick and convenient processing.





## Smart Resume Printing Function

The machine can automatically resume printing after power offer, less worries on print failure.

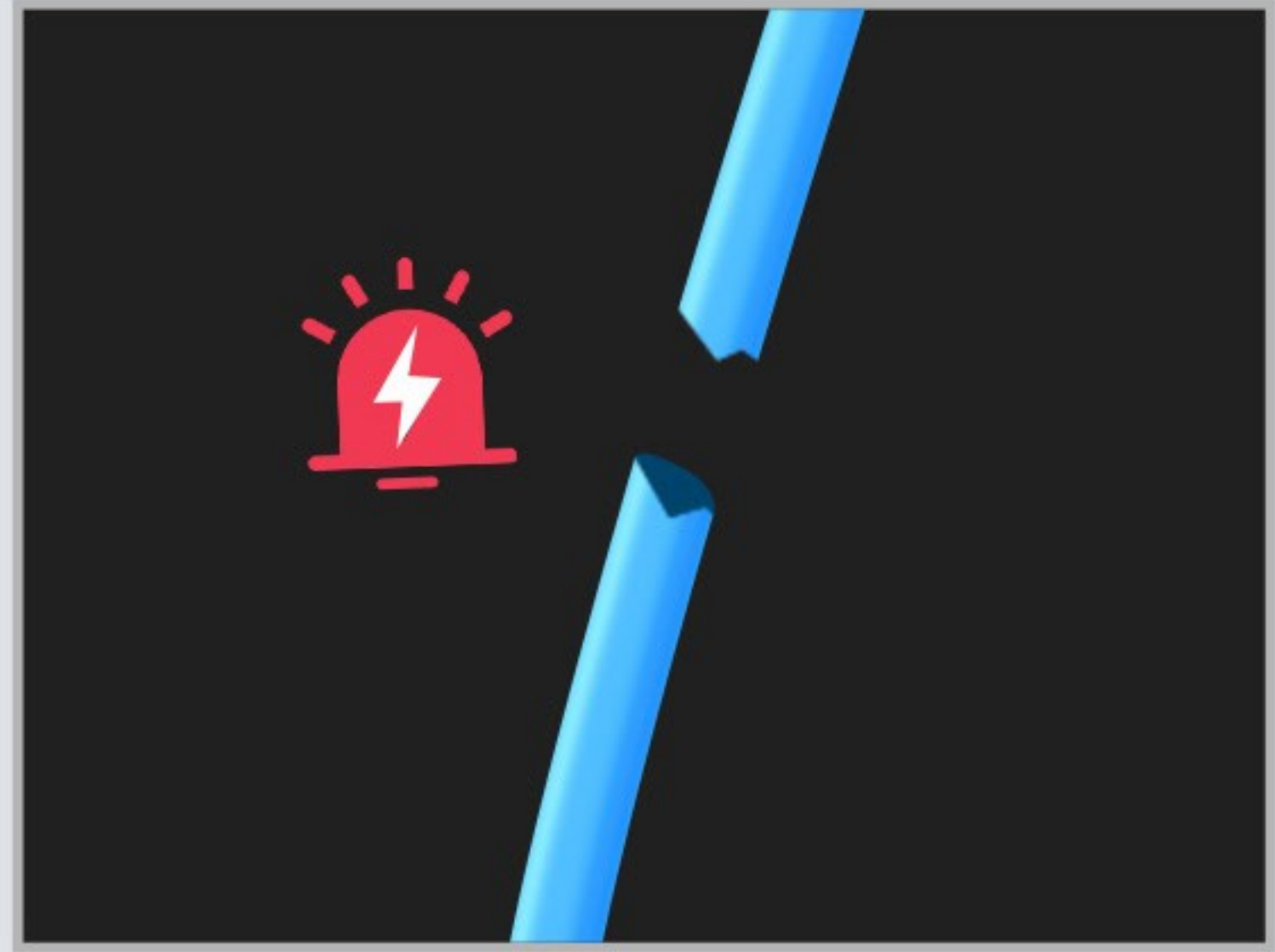

## Automatic Filament Detection

It will pause the printing process, if the filament run out or if the filament is broken.

# Compatible With Various Filaments

## Common filament

PLA, TPU, PETG, etc

## Support filament

S-Multit, S-HtPA, PVA, etc

## Engineering filament

HtPA, PET-GF, PET-CF, PA12-CF, HTPA-GF, HTPA-CF,  
ABS-GF25, ABS-CF20, PA-GF25, PA-CF25, etc



# Applicable Industries

---

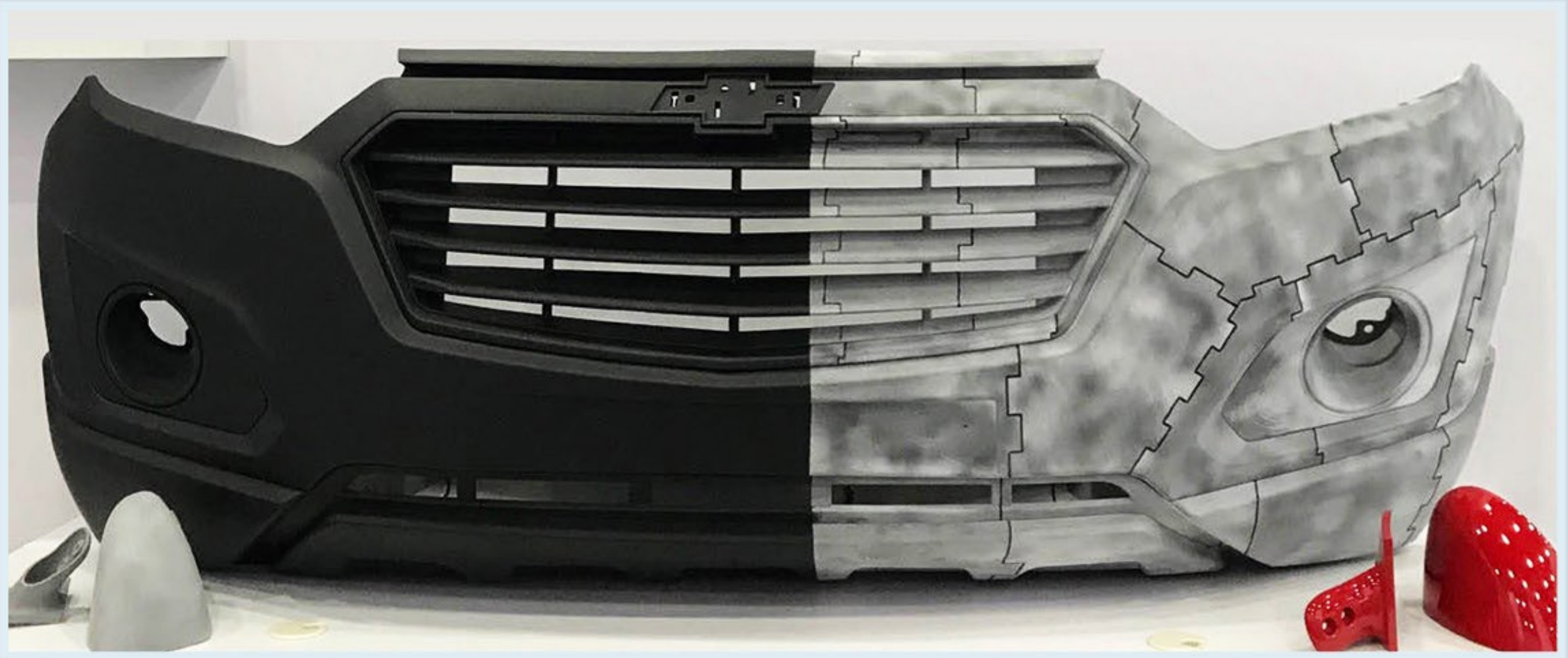

**Automotive industry**

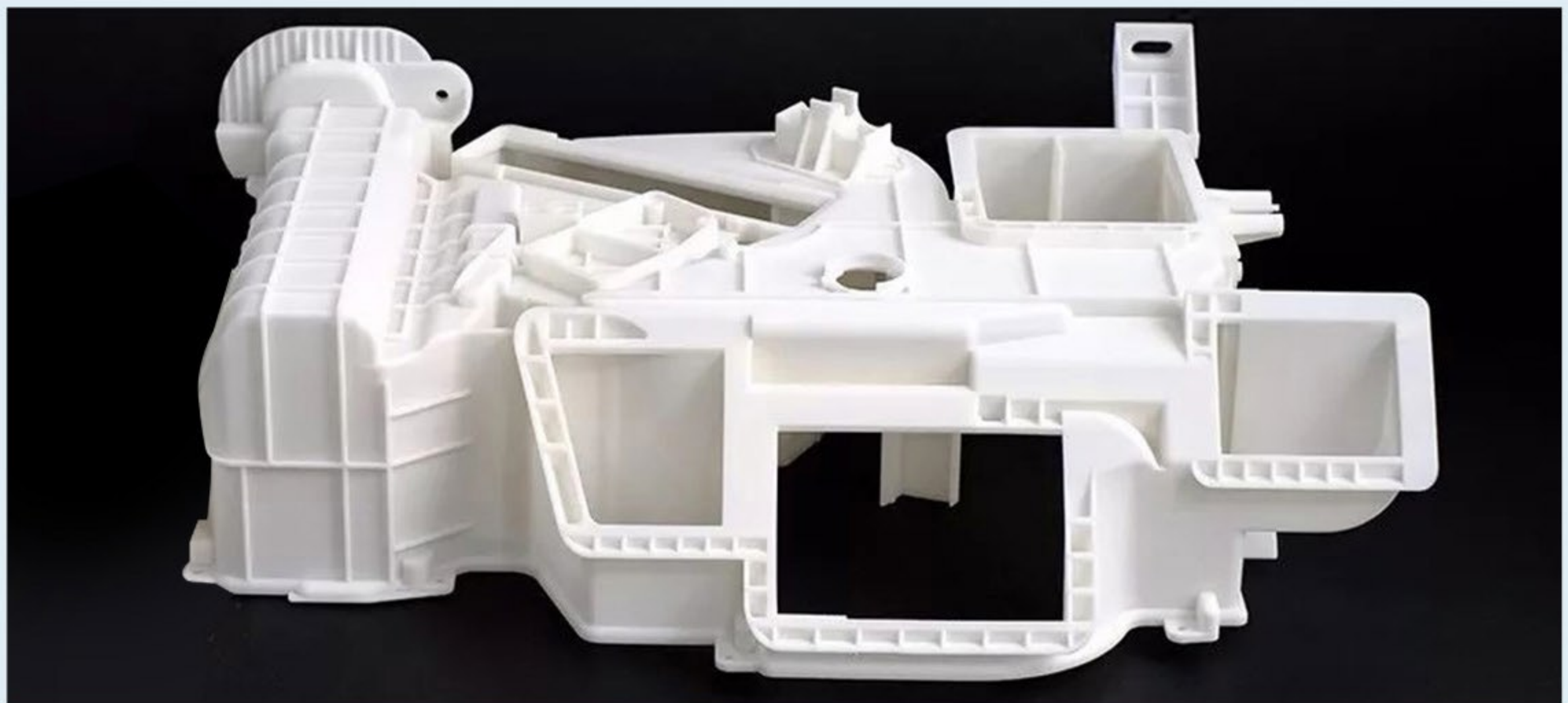

**Functional prototyping**



**Fixture**



**Prototyping and design**



**Portrait**

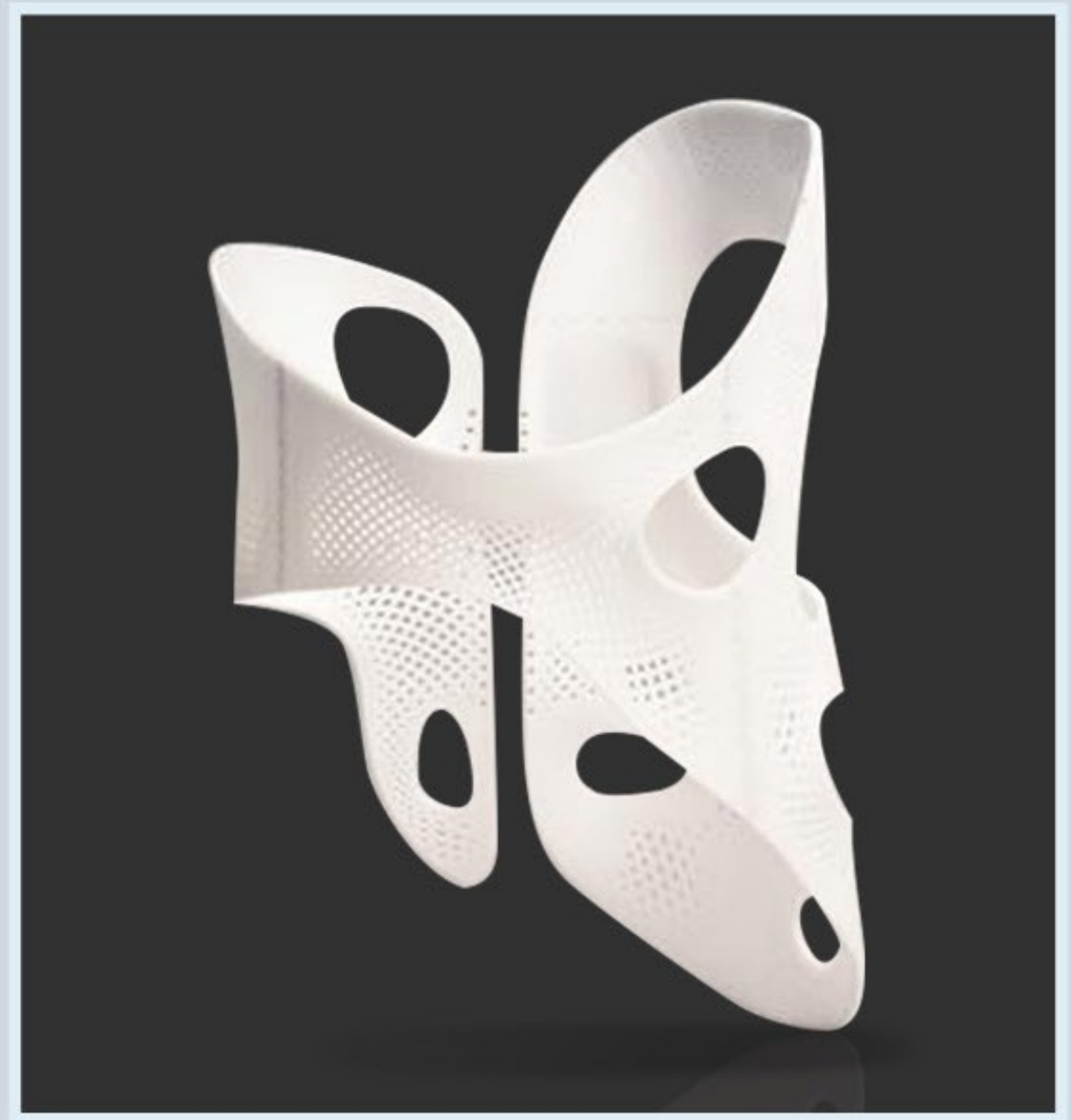

**Medical Industry**

# Product Parameters

Model : MD-1000D

Print Technology : Fused Deposition Modeling(FDM)

Print Volume : 1000\*1000\*1000 mm

Machine Dimensions : 1680\*1365\*1665 mm

Extruder Type: : Dual Extruders

Nozzle Diameter: : 0.4mm (0.6, 0.8, 1.0 mm optional)

Extruder Temperature :  $\leq 350^{\circ}\text{C}$

Platform Temperature :  $\leq 110^{\circ}\text{C}$

Max Flow :  $40\text{mm}^3/\text{s}$

Max Print Speed : 500mm/s  
(Recommend Printing Speed: 200-300mm/s )

Support Software : MingDa OrcaSlicer, Prusa Slicer, etc

Filament Compatibility :  
Common filament: PLA, TPU, PETG;  
Engineering filament: PA-CF/GF, PET-CF/GF,  
HtPA-CF/GF, ABS-GF25, ABS-CF20, PA-GF25/CF25;  
Support filament: S-Mulit, S-HtPA, PVA, etc

Display Screen : 7-inch HDMI touch screen

Input Voltage : 100/240AC 50/60Hz

Rated Power : 2000W (Hot Bed Power: 1800W)

Firmware : klipper